



UNIVERSAL RELEASE BEARING

INSTALLATION INSTRUCTIONS

Thank you for purchasing a Quarter Master release bearing. Please take a few minutes to read through these instructions before you install your new Quarter Master Universal Release Bearing.

CAUTIONS:

- WEAR EYE PROTECTION!
- DO NOT USE DOT 5 SILICONE BRAKE FLUID. DOT 5 brake fluid will damage the o-rings.
- DO NOT OVER-EXTEND THE PISTON. Maximum travel is .625".
- DO NOT WASH SEALS WITH SOLVENT. Solvent may damage the seals. Use isopropyl alcohol or soap and water.

MOUNTING:

- This release bearing does not require shims or adjustments.
 - The release clearance (with the piston completely compressed) should be between .100" and .250". Refer to your clutch instructions for specific information.
 - Front wheel drive cars may require an alternate measurement method when checking release bearing clearance.
 - Bench bleed the master cylinder if possible (see the Bleeding section).
1. Check the release bearing clearance. If the clearance is not within the limits, contact your local Quarter Master distributor for a longer or shorter replacement piston. Refer to Figure 1.
 2. Install the release bearing in place with three 1/4" or 6mm screws.
 3. Install the bellhousing and transmission.
 4. Install the master cylinder, refer to Tables 1 & 2 for sizing recommendations.

BLEEDING:

- Use either DOT 3 or DOT 4 compatible brake fluid.
 - Make sure that the master cylinder reservoir remains full of brake fluid during the bleeding operation.
 - The maximum master cylinder stroke is 1.0".
1. Attach hydraulic lines.
 2. Fill the reservoir with brake fluid.
 3. Bleed the master cylinder and the release bearing to ensure no air is in the lines.

PEDAL STOP:

- Install a pedal stop to prevent over-stroking the clutch.
 - The best place for a pedal stop is at the pedal face.
1. Install a rigid pedal stop to allow near full stroke of the pedal.
 2. Slowly apply pressure to the pedal while applying a torque to the clutch, typically by trying to rotate the driveshaft.
 3. Set the pedal stop near the point where the release is felt.
 4. Adjust the pedal stop to allow approximately 1/4" more of pedal travel at the pedal face past the initial release point.

MAINTENANCE:

- Parts can be lubed with brake fluid or water soluble rubber grease. DO NOT USE PETROLEUM GREASE, LITHIUM GREASE OR MINERAL SPIRITS.
 - All rebuild parts are available separately. Contact your local Quarter Master distributor for more information.
1. Check the bearing by spinning it by hand. It should spin smoothly.
 2. Check the fittings for leaks.
 3. Check for leaks around the piston.
 4. Remove the piston and check for dirt, debris or burrs.

REPLACEMENT PARTS:

- Refer to Table 3 for piston and bearing replacement part numbers.
- Seal Rebuild Kit is Q.M.I. P/N 730101, which includes the major seal, wiper seal and AN fitting seals.

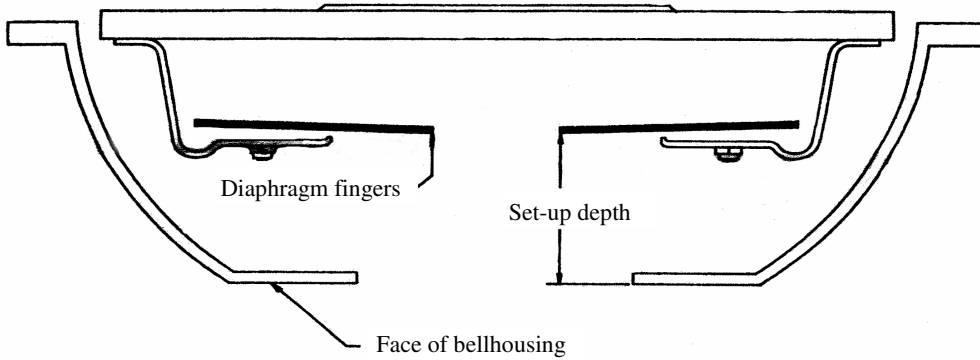

Set-up Depth: _____
 - Overall Bearing Height: _____
 = Bearing Clearance: _____

Figure 1: Set-up Depth Measurement

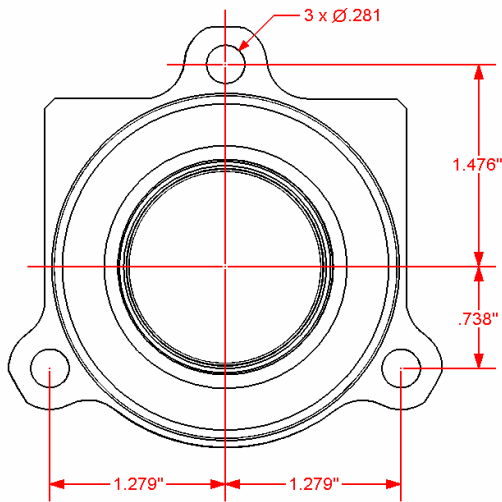

Figure 2: Bolt pattern of the Universal assembly

Table 1: Typical Release Bearing Travel

Quarter Master Clutches	Bearing Travel
4.5" Clutches	.120"
5.5" Clutches	.150"
7.25" Clutches	.140"
8.5" Clutches	.180"

Table 2: Equivalent Release Bearing Travel

Master Cylinder Size	Bearing Travel (assuming 1.0" of master stroke)
5/8"	.25"
7/10"	.31"
3/4" (19 mm)	.36"
13/16"	.42"
7/8"	.49"
15/16"	.56"

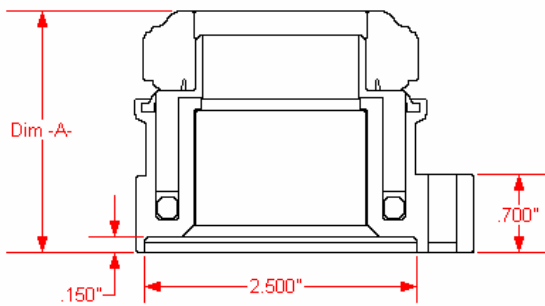

Figure 3: Side-view of Universal assembly

Table 3: Piston and Bearing Dimensions

Part Number Assy / Piston & Brg	Piston & Bearing Length	Dimension -A-
740165 / 741165	1.650"	2.210"
740175 / 741175	1.750"	2.310"